

rexresearch.com

US Patents: Disc Aircraft

(Propellor & Jet-Driven Wingless Aerodynes, Lenticular Aircraft, Discoid Aircraft, &c.
This file does not include force field propulsion & space drives)

Acknowledgements: Visit Man-Made Flying Saucers (<http://www.aspubs.com/mmsaucers/>) and World Space Drive Archives for a thorough treatment of this subject, plus: anti-gravity and space drive (unidirectional motion rectifiers) patents from around the world, and lots of photos, documentation, &c...

**USP # 6,270,036 (8-7-01) ~ Blown-Air Lift
Generating Rotating Airfoil Aircraft
Lowe, Charles S., Jr.**

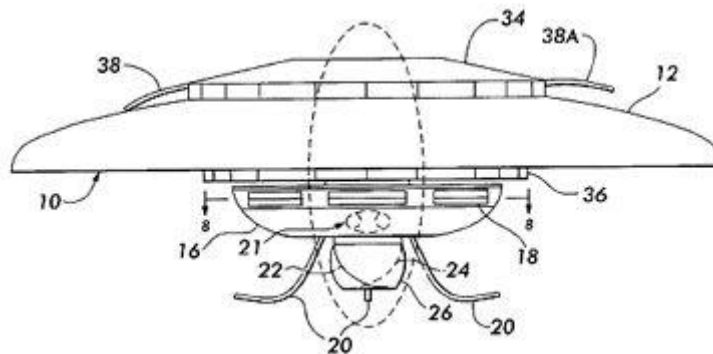

**USP # 6,254,032 (7-3-01) ~ Aircraft, &c...
Bucher, Franz**

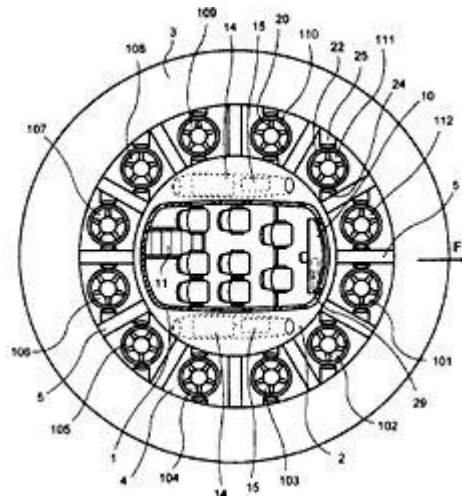

**USP # 6,179,247 (1-30-01) ~ Personal Air
Transport
Milde, Jr., Karl F.**

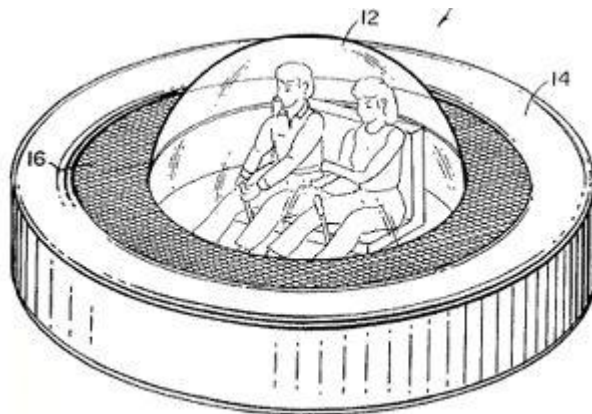

**USP # 6,113,029 (9-5-00) ~ Aircraft Capable of
Hovering Flight
Salinas, Luis A.**

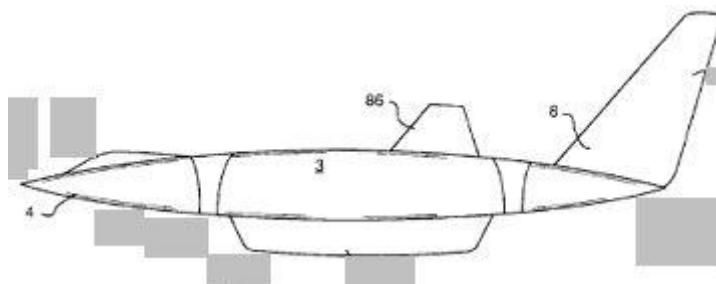

**USP # 6,082,478 (7-4-00) ~ Lift-Augmented
Ground Effect Platform
Walter, William. C., et al.**

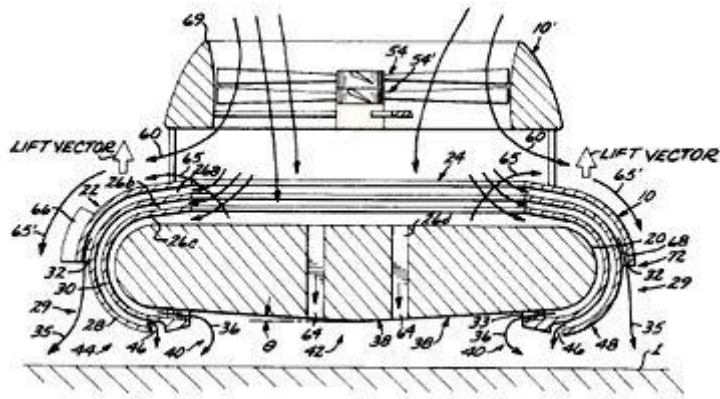

**USP # 6,073,881 (6-13-00) ~ Aerodynamic Lift
Apparatus
Chen, Chung-ching**

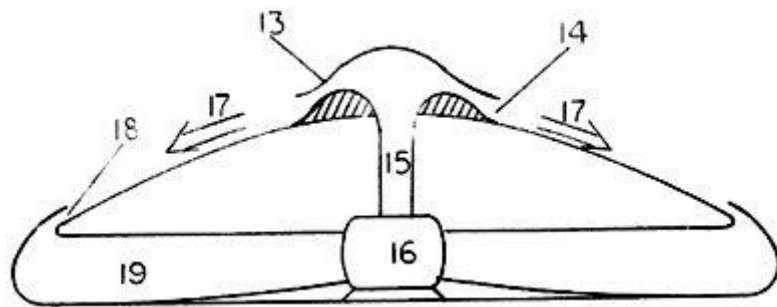

**USP # 6,068,219 (5-30-00) ~ Single-Surface
Multi-Axis Aircraft Control
Arata, Allen A.**

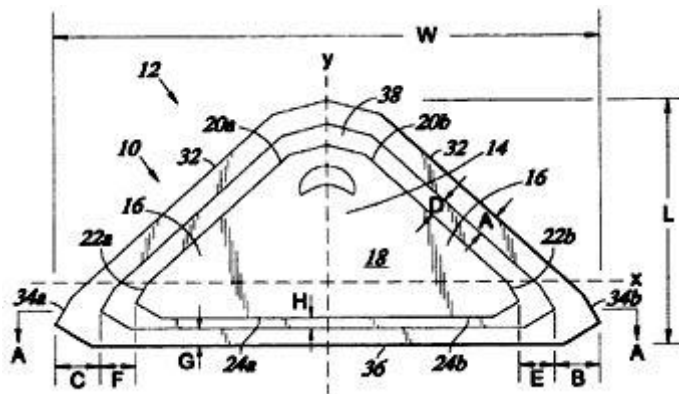

**USP # 6,053,451 (4-25-00) ~ Remote-Control
Flight Vehicle Structure
Yu, Shia-Giow**

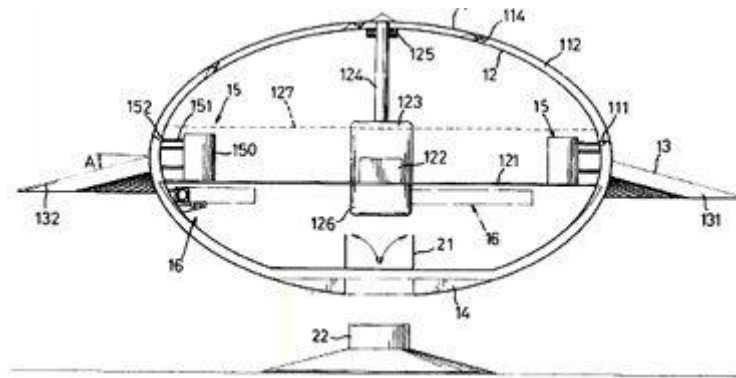

**USP # 6,050,520 (4-18-00) ~ VTOL Aircraft
Kirla, Stanley J.**

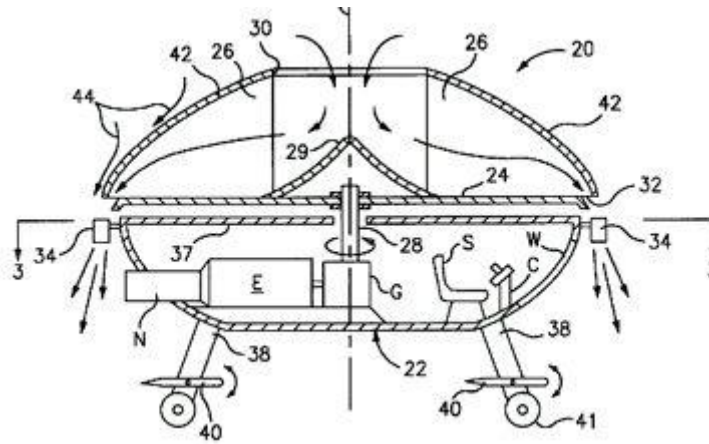

**USP # 6,016,991 (1-25-00) ~ Evacuated Rotating
Envelope Aircraft
Lowe, Jr., Charles S.**

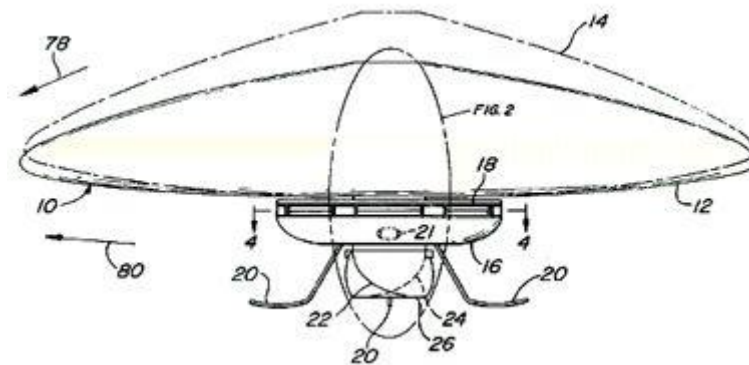

**USP # 5,881,970 (3-16-99) ~ Levity Aircraft
Design
Whitesides, Carl W.**

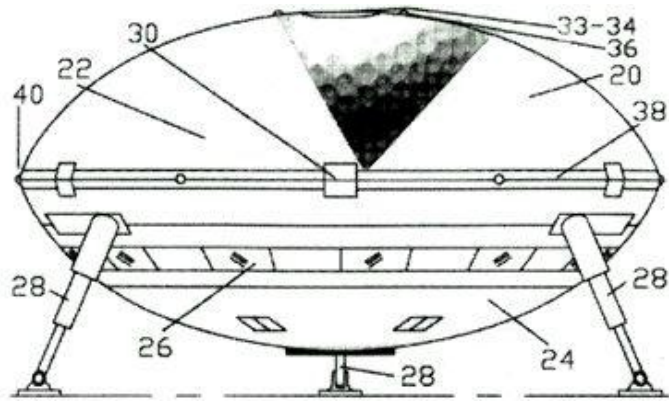

**USP # 5,836,543 (11-17-98) ~ Discus-Shaped
Aerodyne Vehicle...
Kunkel, Klaus**

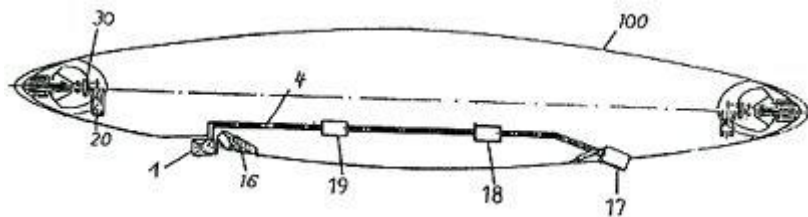

**USP # 5,836,542 (11-17-98) ~ Flying Craft &c...
Burns, David J.**

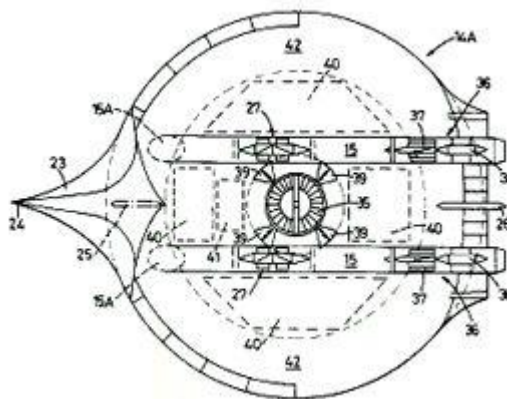

**USP # 5,803,199 (9-8-98) ~ Lift-Augmented
Ground Effect Platform
Walter, William C.**

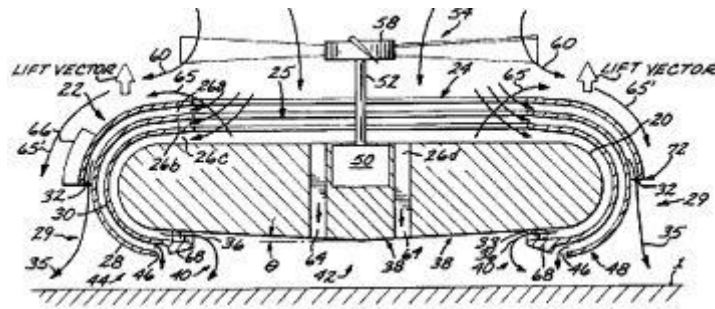

**USP # 5,730,391 (3-24-98) ~ Universal Fluid-
Dynamic Body for Aircraft & Watercraft
Miller, Jr., John A., et al.**

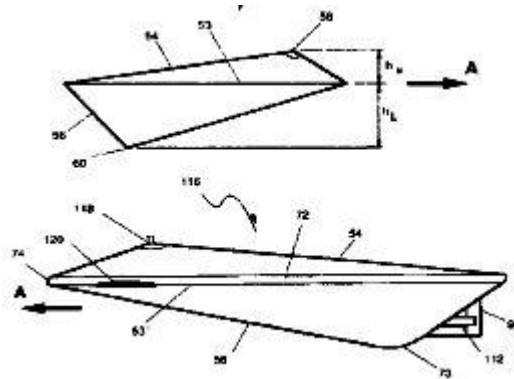

**USP # 5,730,390 (3-24-98) ~ Reuseable
Spacecraft
Plichta, Peter & Buttner, Walter**

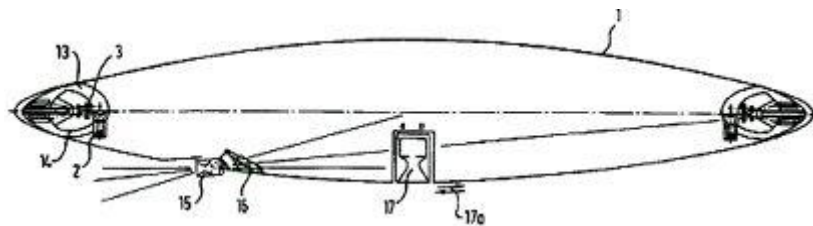

USP # 5,344,100 (9-6-94) ~ Vertical Lift Aircraft
Jaikaran, Allan

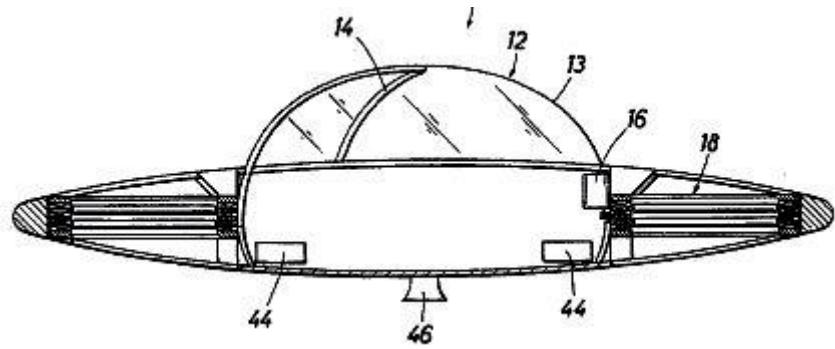

USP # 5,318,248 (6-7-94) ~ Vertical Lift Aircraft
Zielonka, Richard H.

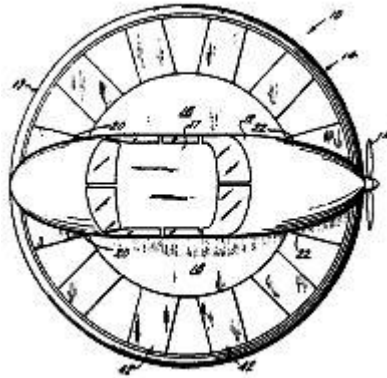

USP # 5,303,879 (4-19-94) ~ Aircraft with a Ducted Fan in a Circular Wing
Bucher, Franz

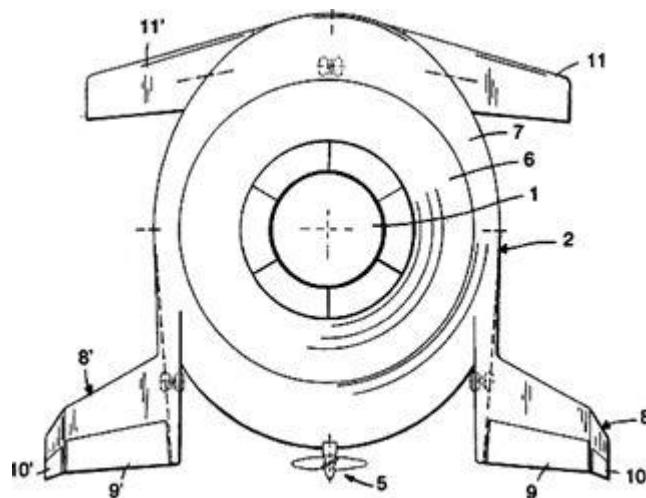

USP # 5,295,571 (11-9-93) ~ Aircraft with Gyroscopic Stabilization System
Blazquez, Jose M.

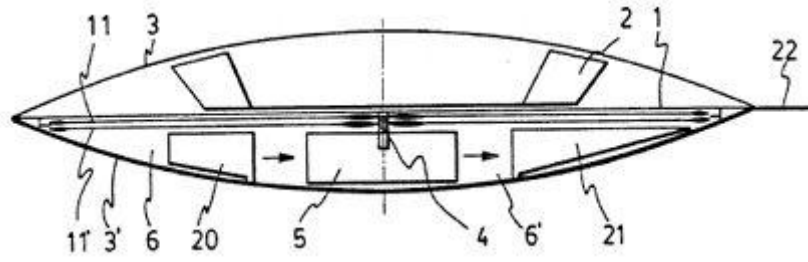

USP # 5,213,284 (5-25-93) ~ Disc Planform having Vertical Flight Capability
Webster, Stephen N.

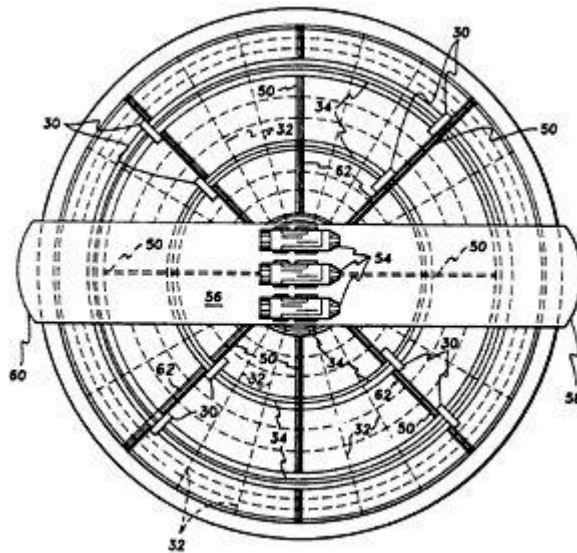

USP # 5,203,521 (4-20-93) ~ Annular Body Aircraft
Day, Terence

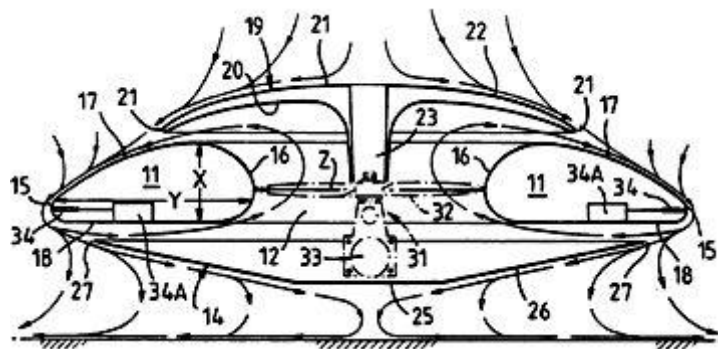

**USP # 5,178,344 (1-12-93) ~ VTOL Aircraft
Dlouhy, Vaclav**

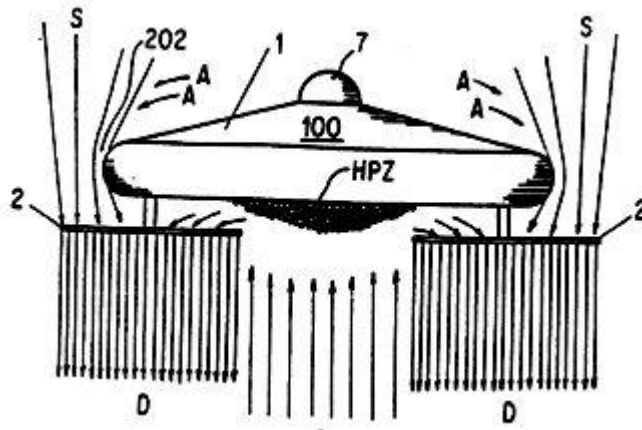

**USP # 5,170,963 (12-15-92) ~ VTOL Aircraft
Beck, Jr., August H.**

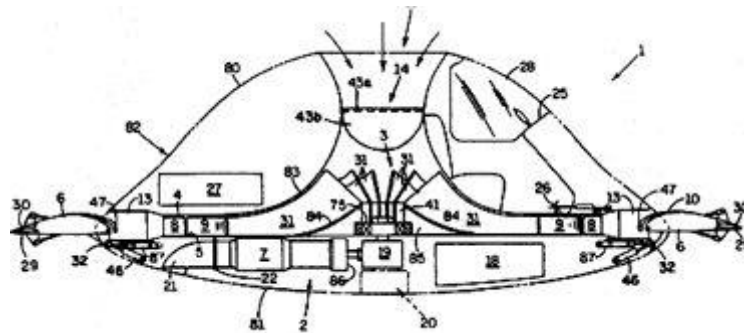

**USP # 5,149,012 (9-22-92) ~ Turbocraft
Valverde, Rene L.**

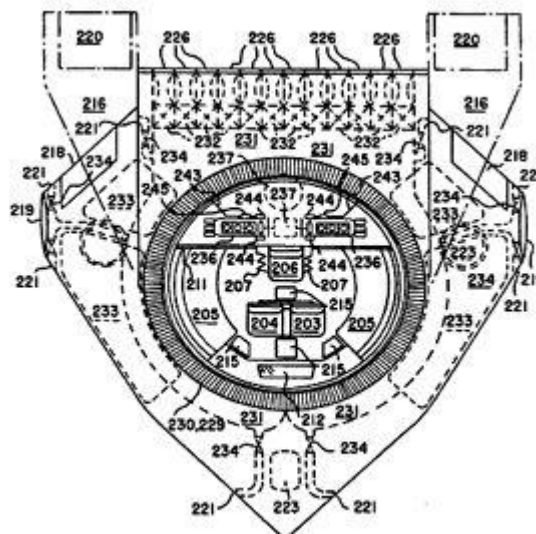

USP # 5,115,996 (5-26-92) ~ VTOL Aircraft
Moller, Paul S.

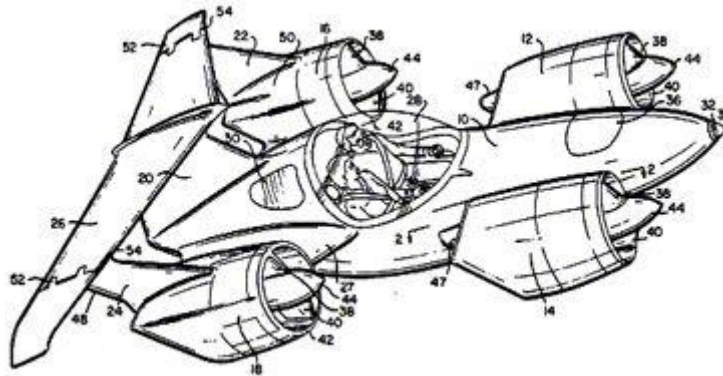

USP # 5,102,066 (4-7-92) ~ VTOL Aircraft
Daniel, William H.

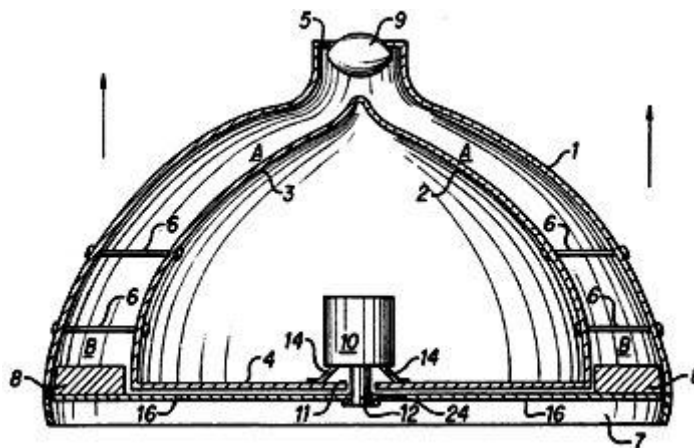

**USP # 5,064,143 (11-12-91) ~ Aircraft Having a
Pair of Counter Rotating Rotors
Bucher, Franz**

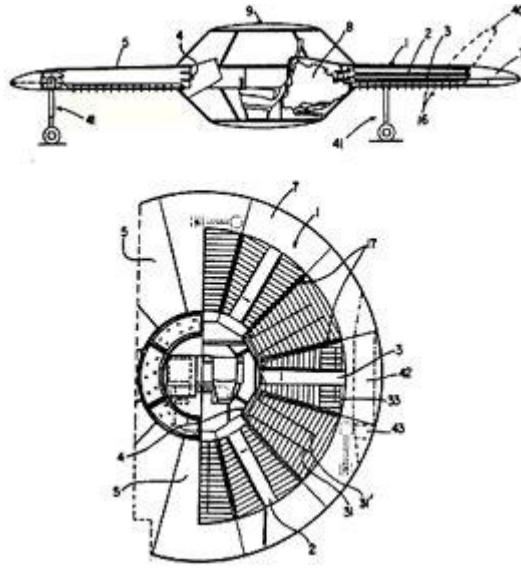

**USP # 5,054,713 (10-8-91) ~ Circular Airplane
Langley, Lawrence W., et al.**

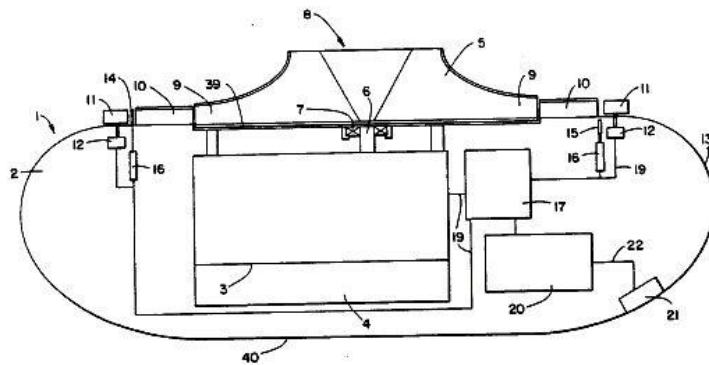

USP # 5,046,685 (9-10-91) ~ Fixed Circular Wing Aircraft
Bose, Phillip R.

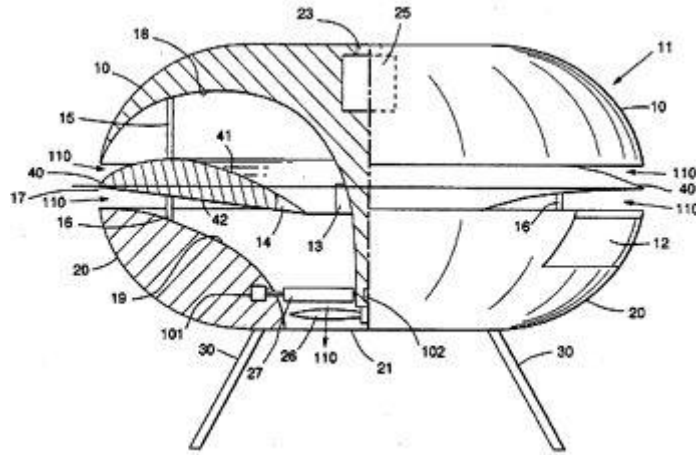

USP # 5,039,031 (8-13-91) ~ Turbocraft
Valverde, Rene L.

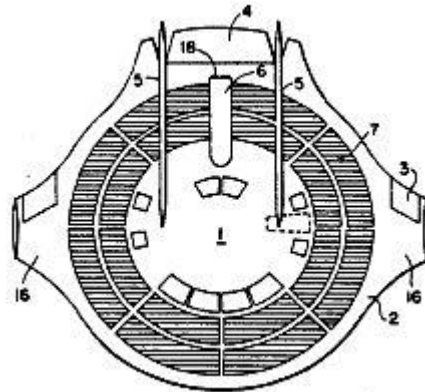

USP # 4,976,395 (12-11-99) ~ Heavier-Than-Air Disk-Type Aircraft
von Kozierowski, Joachim

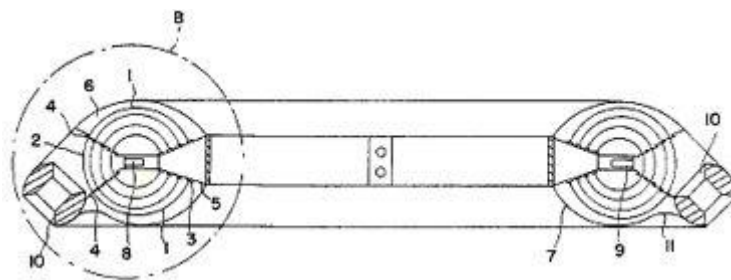

**USP # 4,955,962 (9-11-99) ~ Remote Control
Flying Saucer
Mell, Christian**

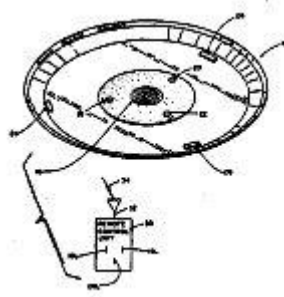

**USP # 4,941,628 (7-19-90) ~ Lift Generating
Apparatus, &c.
Sakamoto, Yujiro, *et al.***

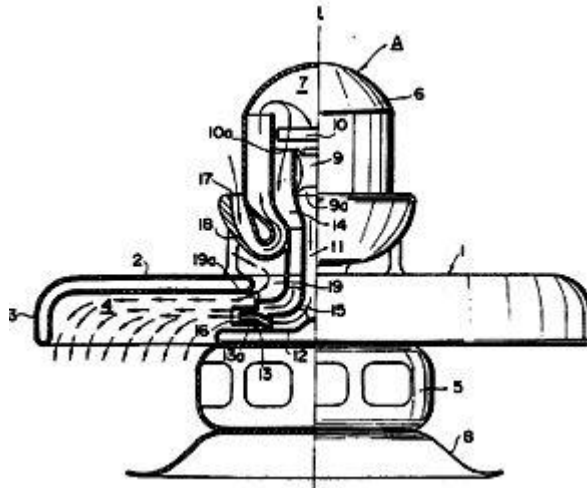

**USP # 4,824,048 (4-25-89) ~ Induction Lift
Flying Saucer
Kim, Kyusik**

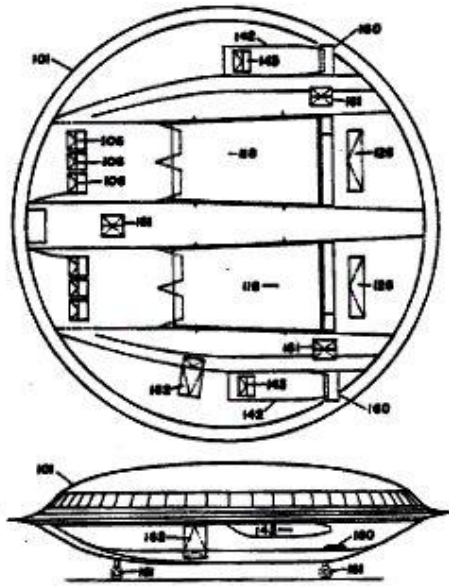

**USP # 4,804,156 (2-14-89) ~ Circular Aircraft
Harmon, Rodney D.**

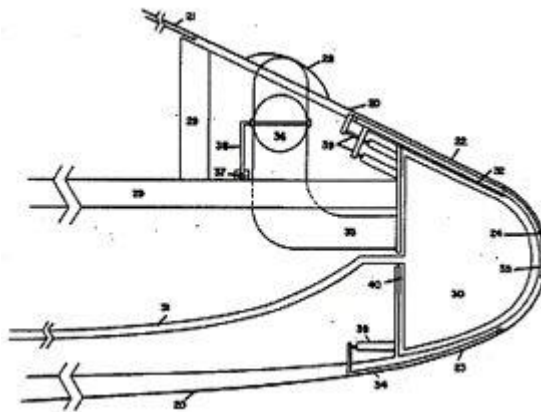

USP # 4,796,836 (1-10-89) ~ Lifting Engine for VTOL Aircrafts
Buchelt, Benno

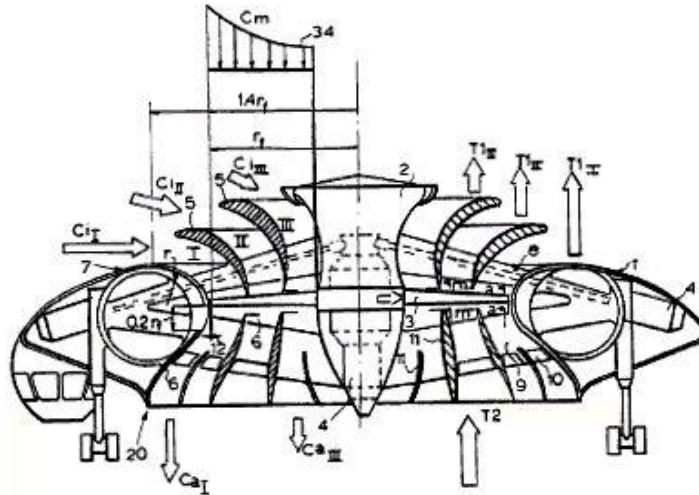

USP # 4,795,111 (1-3-89) ~ Robotic or Remotely Controlled Flying Platform
Moller, Paul S.

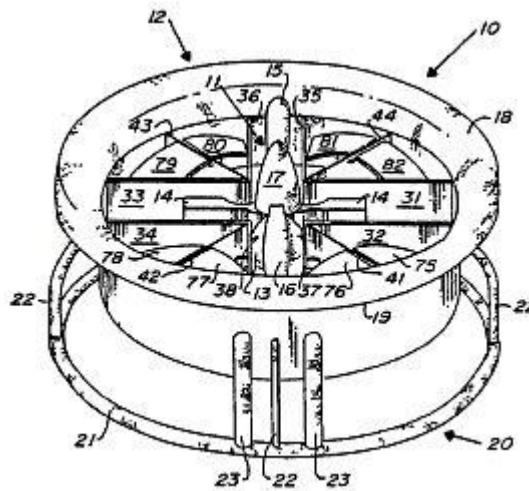

USP # 4,214,720 (7-29-80) ~ Flying Disc
DeSautel, Edwin R.

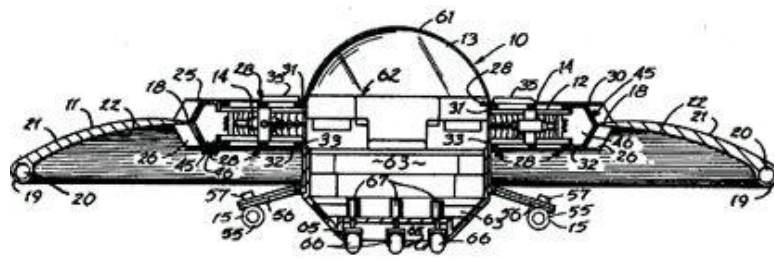

USP # 4,165,848 (8-28-79) ~ Rotary Thrust Device...
Bizzarri, Alfredo

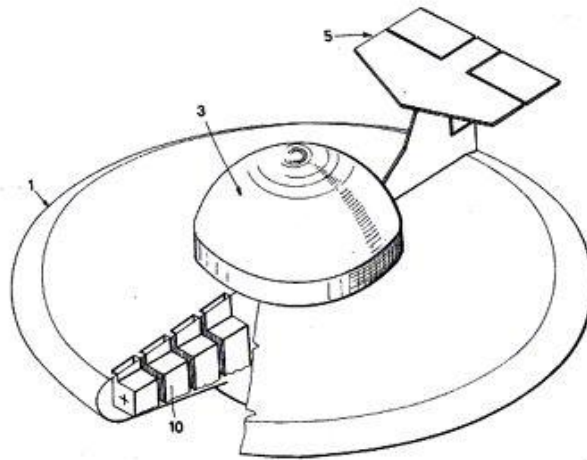

USP # 4,117,992 (10-3-78) ~ Vertical Lift Device
Vrana, Charles K.

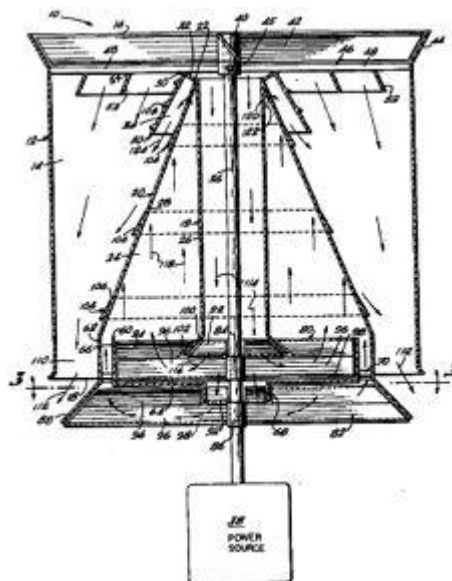

USP # 4,050,652 (9-27-77) ~ Gyro Foil
DeToia, Vincent D.

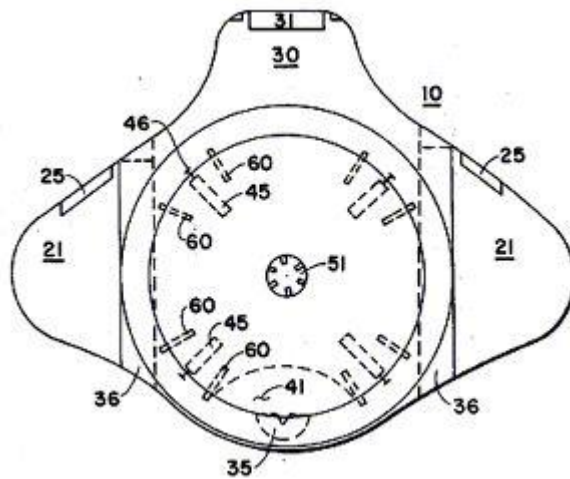

USP # 4,023,751 (5-17-77) ~ Flying Ship
Richard, Walter A.

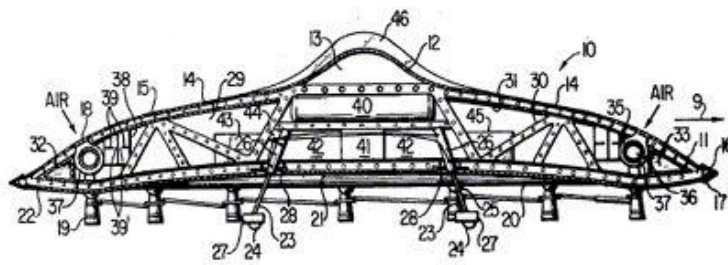

USP # 4,014,483 (3-29-77) ~ Lighter-Than-Air Craft
MacNeil, Roderick M.

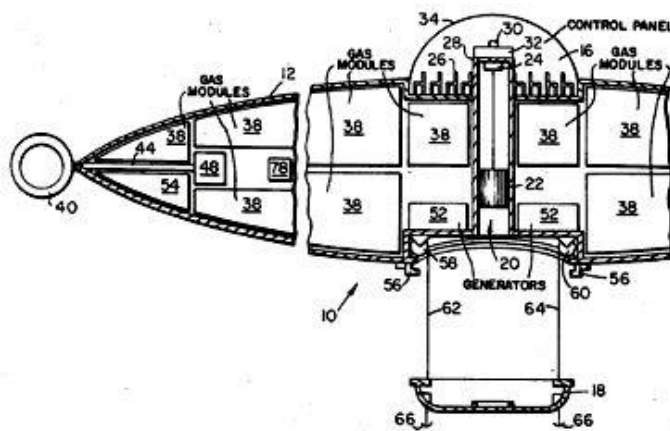

**USP # 3,933,325 (1-20-76) ~ Disc-Shaped
Aerospacecraft
Kaelin, Joseph R.**

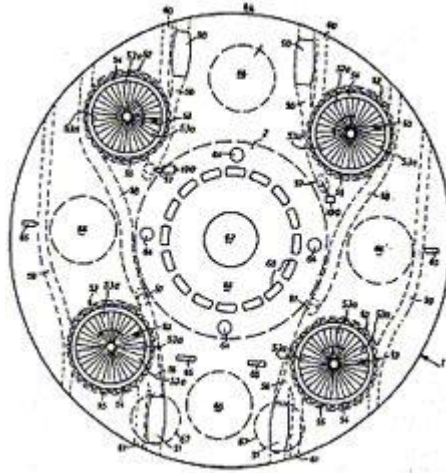

**USP # 3,871,602 (3-18-75) ~ Circular Wing
Aircraft
Kissinger, Curtis D.**

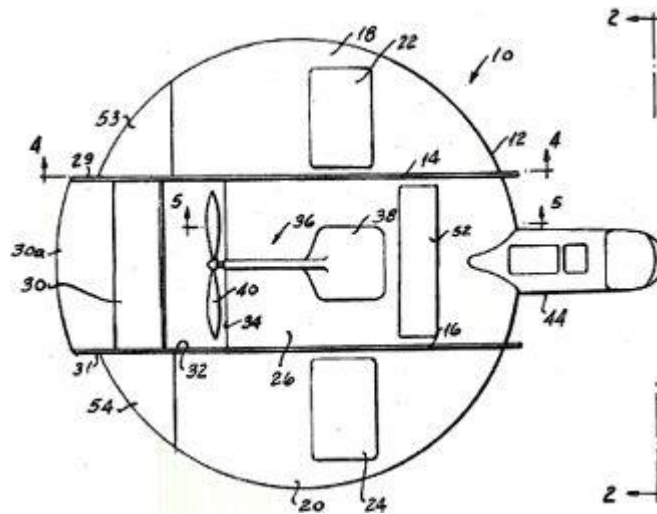

USP # 3,774,865 (11-27-73) ~ Flying Saucer
Pinto, Olympio F.

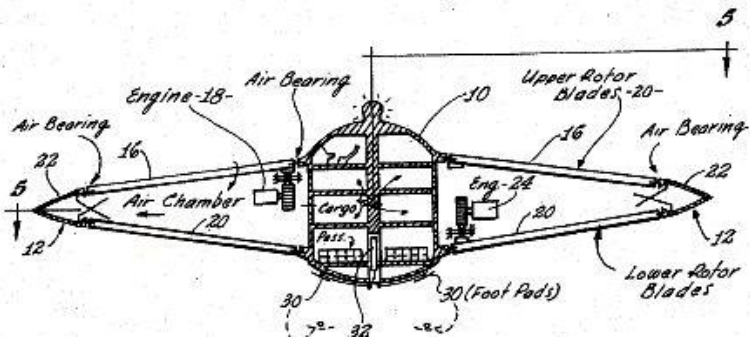

USP # 3,750,980 (8-7-73) ~ Aircraft with VTOL Capability
Edwards, Samuel L.

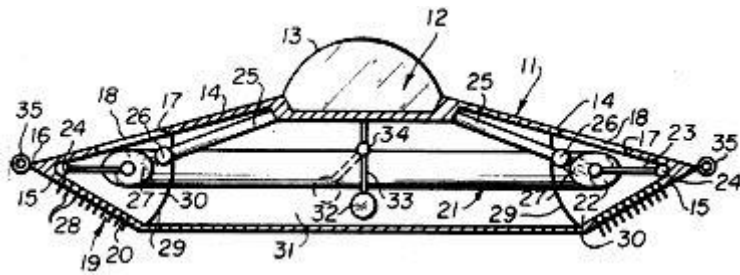

USP # 3,697,020 (10-10-72) ~ Vertical Lift Machine
Thompson, Raymond V.

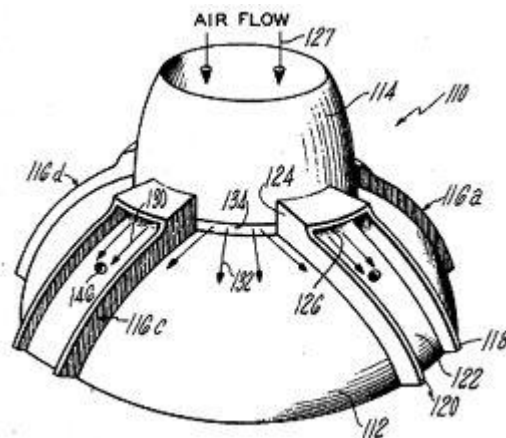

USP # 3,690,597 (9-12-72) ~ VTOL Aircraft...
Di Martino, Renato

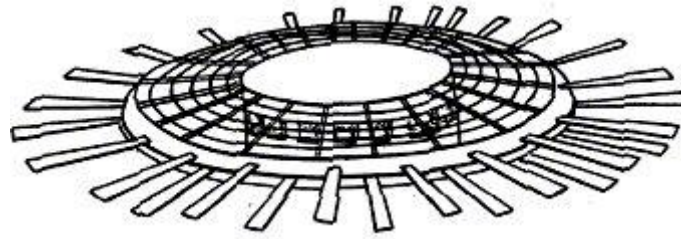

USP # 3,640,489 (2-8-72) ~ VTOL Aircraft
Jaeger, Karl

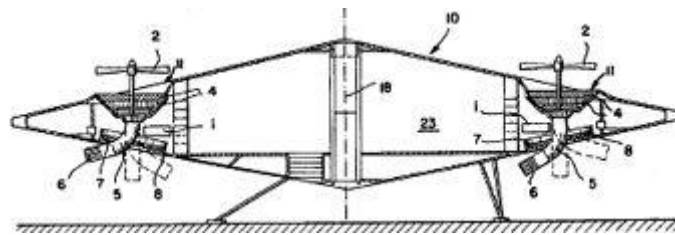

USP # 3,630,470 (12-28-71) ~ VTOL Vehicle
Elliot, Frederick T.

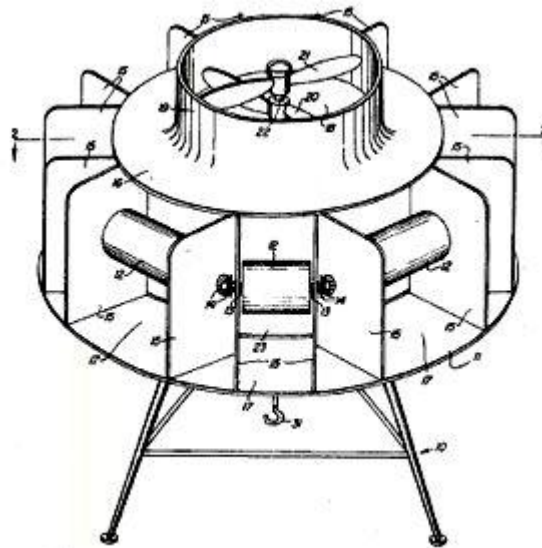

**USP # 3,614,030 (10-19-71) ~ Aircraft
Moller, Paul S.**

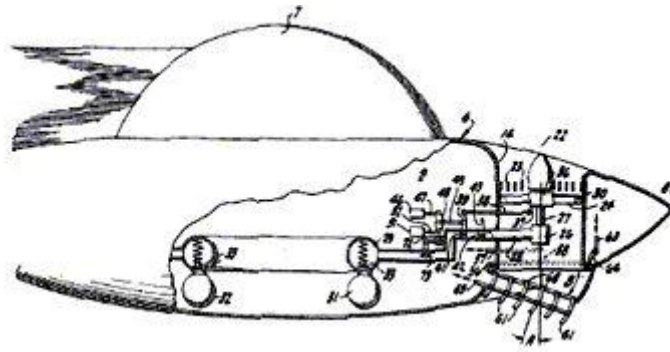

**USP # 3,612,445 (10-12-71) ~ Lift Actuator Disc
Phillips, Duan A.**

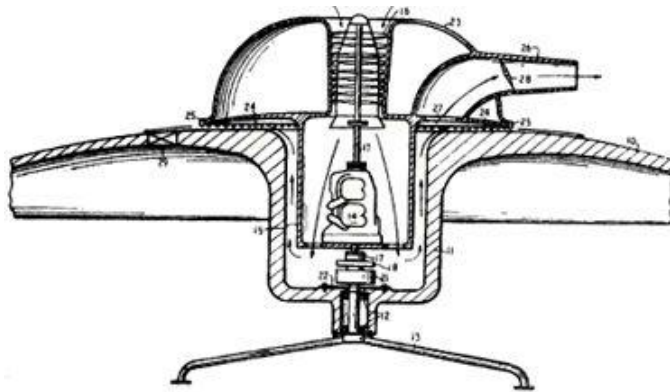

**USP # 3,599,902 (8-17-71) ~ Aircraft
Thomley, John W.**

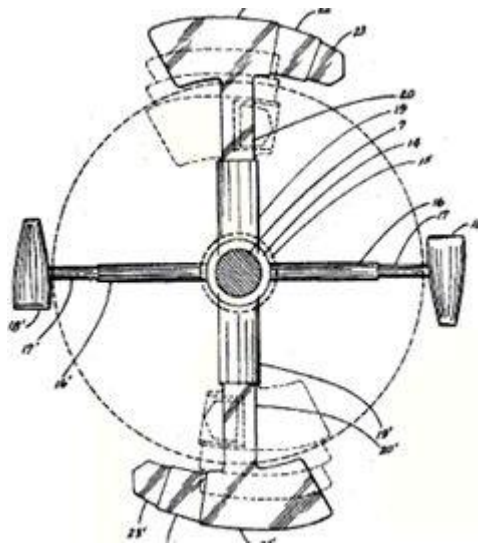

USP # 3,537,669 (11-3-70) ~ Manned Disc-Shaped Flying Craft
Modesti, James N.

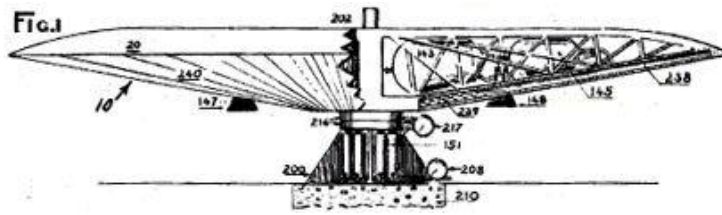

USP # 3,503,573 (3-31-70) ~ Disk Flying Craft
Modesti, James N.

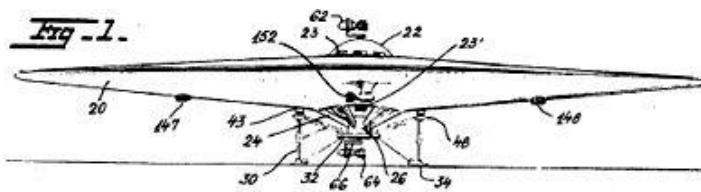

USP # 3,469,802 (9-30-69) ~ Transport
Roberts, J. R., et al.

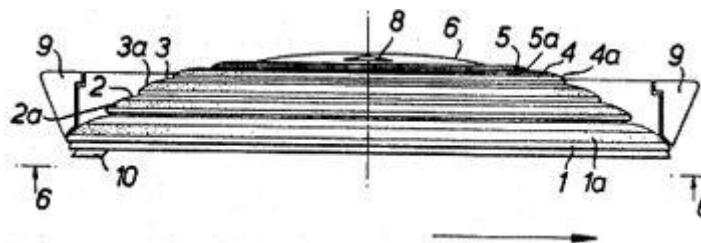

**USP # 3,437,290 (4-8-69) ~ Vertical Lift Aircraft
Norman, Francis A.**

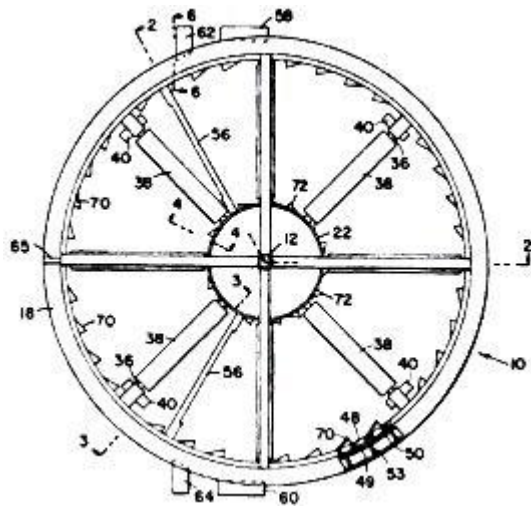

**USP # 3,432,120 (4-11-69) ~ Aircraft
Guerrero, E.**

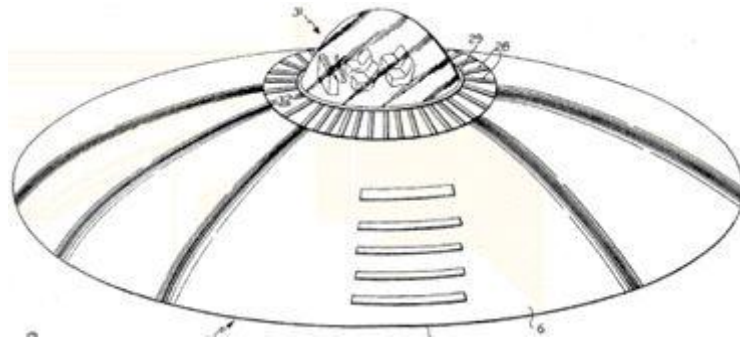

**USP # 3,410,507 (11-12-68) ~ Aircraft
Moller, Paul S.**

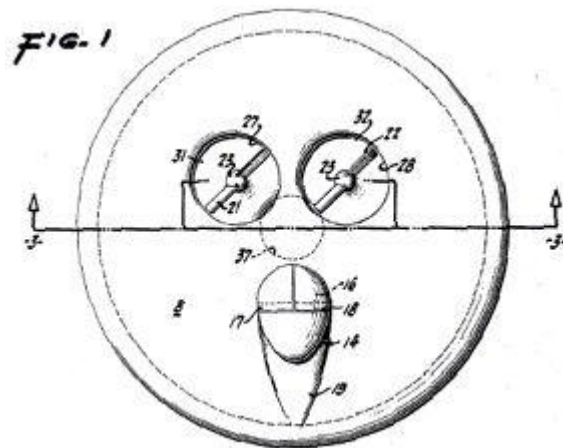

USP # 3,397,853 (8-20-68) ~ Fluid-Sustained Vehicle
Richardson, William. B.

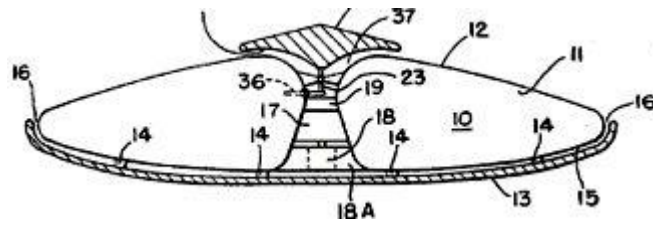

USP # 3,395,876 (8-6-68) ~ Aircraft with Housed Counter-Rotating Propellers
Green, Jacob B.

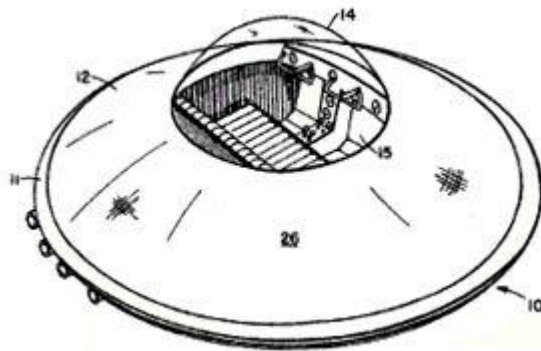

USP # 3,387,801 (6-11-68) ~ VTOL Aircraft
Kelsey, C. W.

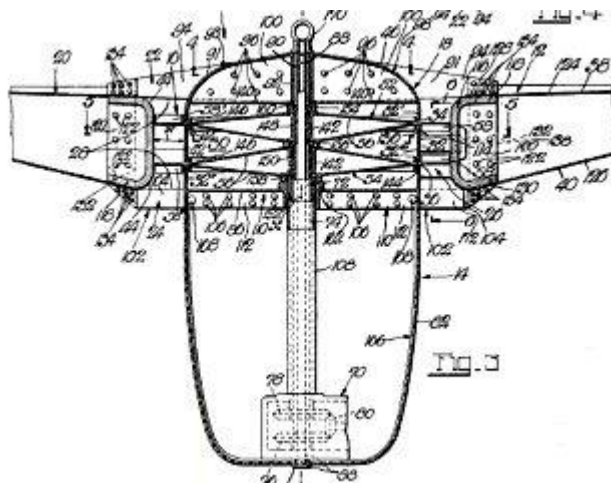

**USP # 3,321,156 (5-23-67) ~ Universally
Manuverable Aircraft
McMasters, Douglas Q.**

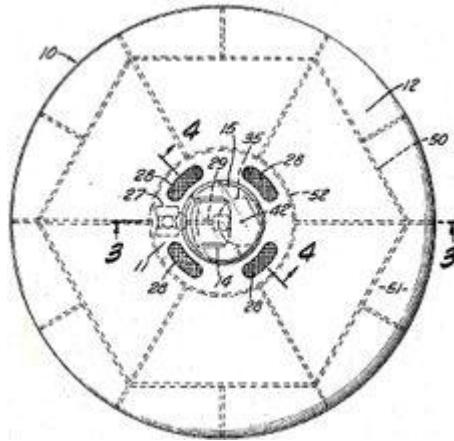

**USP # 3,312,425 (4-4-67) ~ Aircraft
Lennon, C. D., et al.**

FIG. 1.

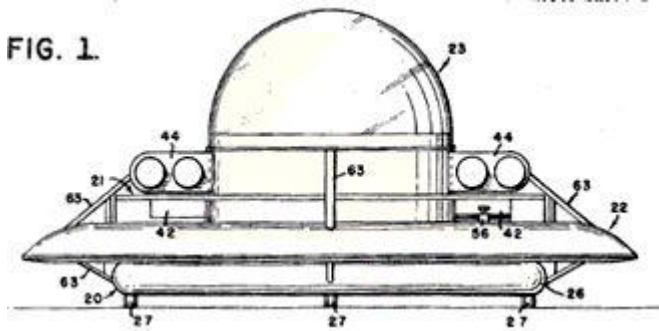

**USP # 3,243,146 (3-29-66) ~ VTOL Aircraft
Clover, P. B.**

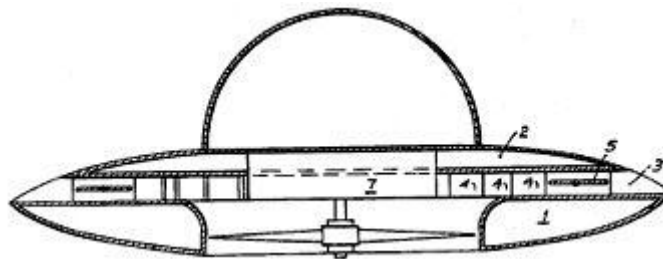

**USP # 3,237,888 (3-1-66) ~ Aircraft
Willis, William M.**

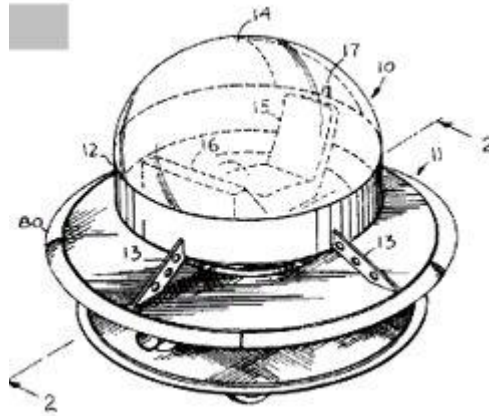

**USP # 3,199,809 (8-10-65) ~ Circular Wing
Flying Craft
Modesti, James N.**

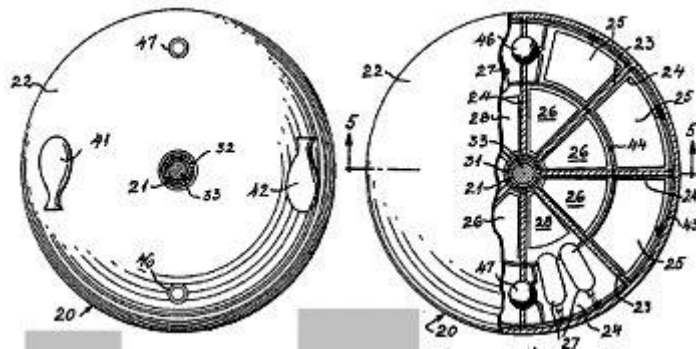

USP # 3,182,929 (5-11-65) ~ VTOL Aircraft
Lemberger, Robert A.

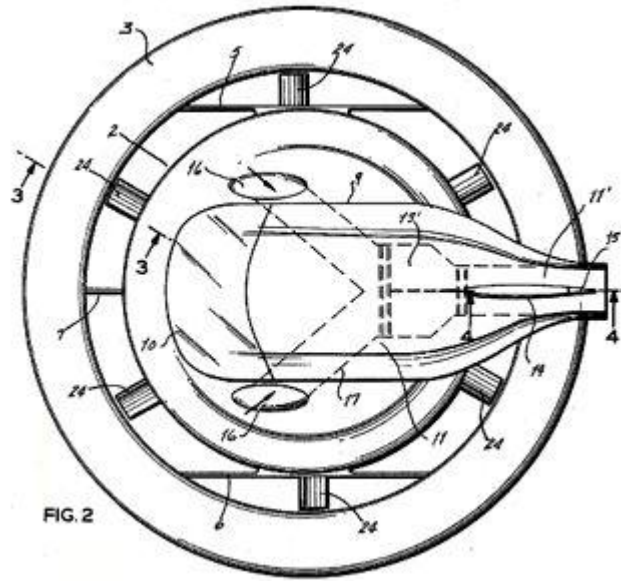

USP # 3,124,323 (3-10-64) ~ Aircraft Propulsion
& Control
Frost, John C. M.

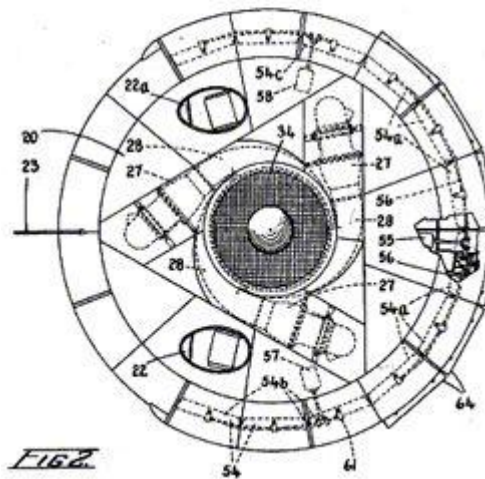
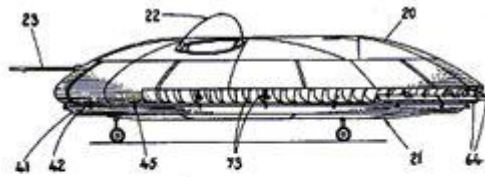

**USP # 3,123,320 (4-3-64) ~ Vertical Rise Aircraft
Slaughter, E. E.**

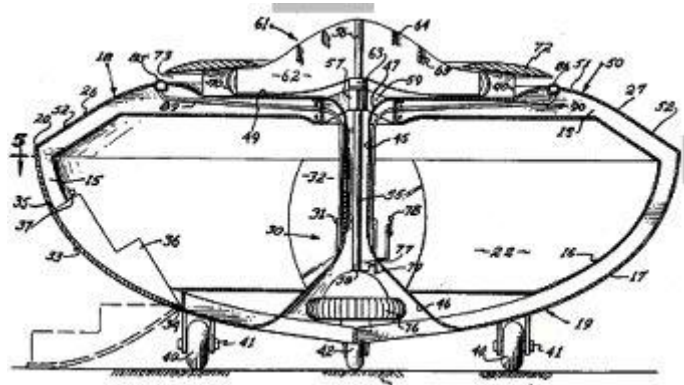

**USP # 3,073,551 (1-15-63) ~ Vertical Lift
Aircraft
Bowersox, Joseph W.**

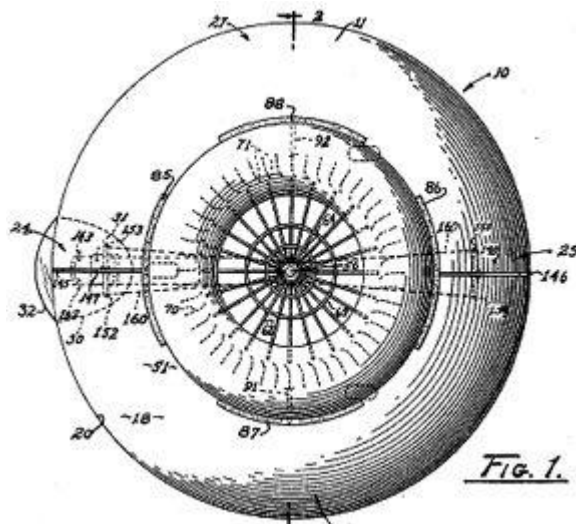

**USP # 3,072,366 (1-8-63) ~ Fluid-Sustained
Aircraft
Freeland, Leonor Z.**

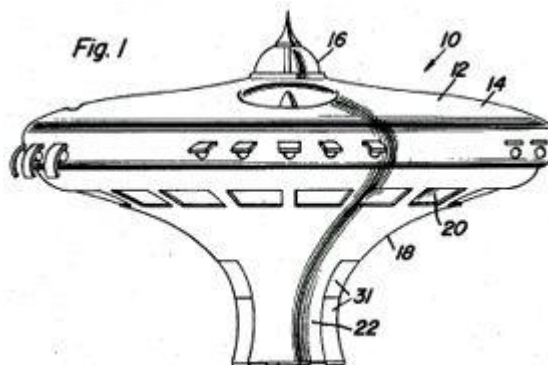

**USP # 3,067,967 (12-11-62) ~ Flying Machine
Barr, I. R.**

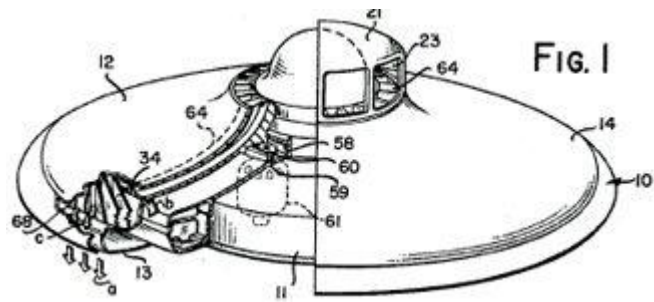

**USP # 3,066,890 (12-4-62) ~ Supersonic Aircraft
Price, Nathan C.**

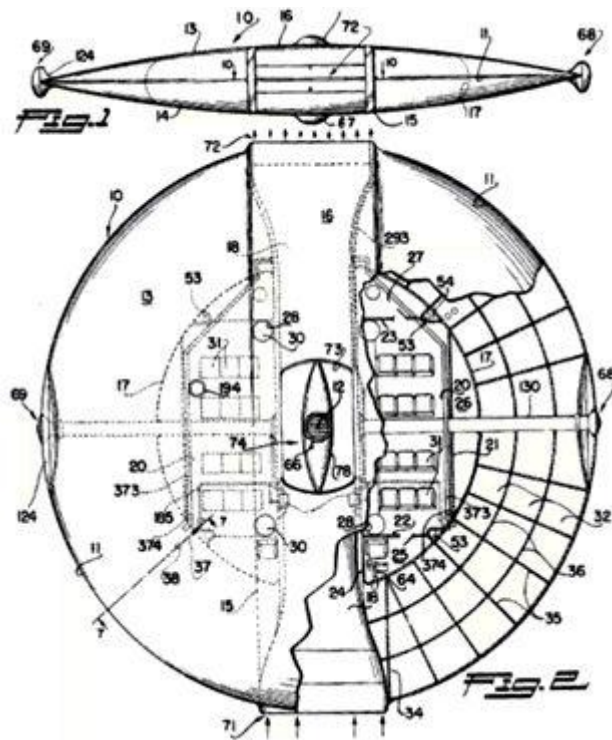

USP # 3,065,935 (11-27-62) ~ VTOL Aircraft
Dubbury, J., et al.

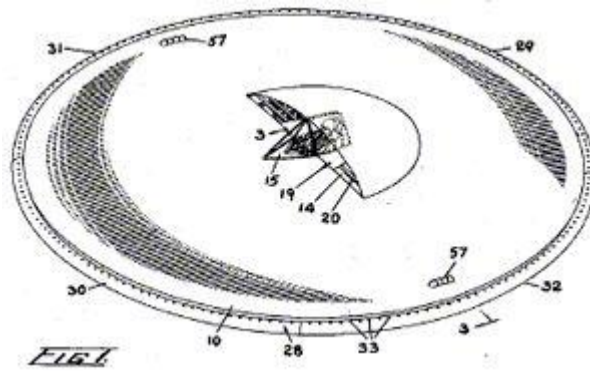

USP # 3,051,417 (8-28-62) ~ Aircraft Control Systems
Frost, John C. M., et al.

USP # 3,051,415 (8-28-62) ~ Fluid-Sustained Aircraft
Frost, John C. M.

USP # 3,051,414 (8-28-62) ~ Aircraft with Jet Fluid Control Ring
Frost, John C. M.

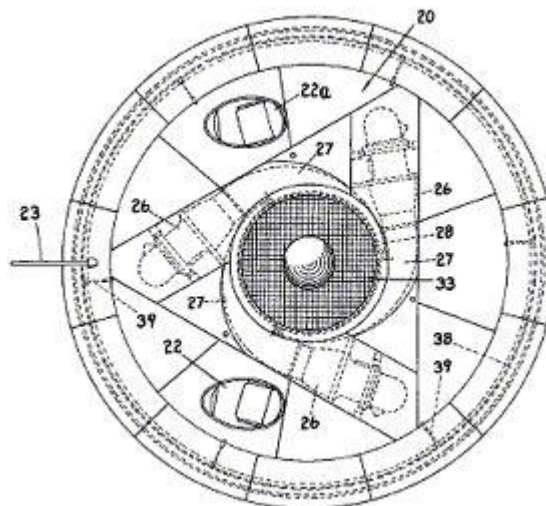

USP # 3,024,966 (3-13-62) ~ Radial Flow Gas Turbine Engine Rotor Bearing
Frost, John C. M.

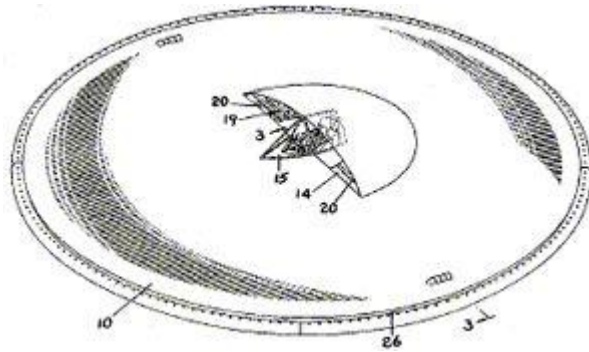

USP # 3,022,963 (2-27-62) ~ Disc-type Aircraft...
Frost, John C. M., et al.

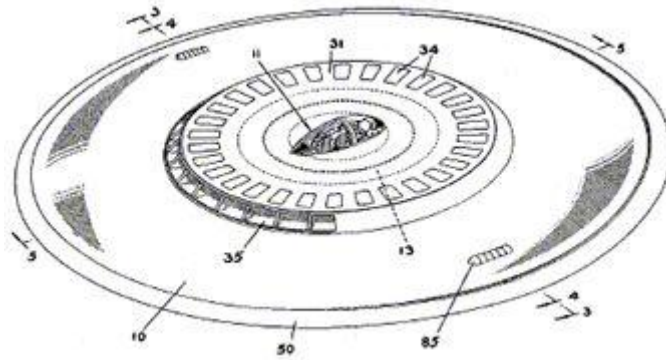

USP # 3,020,003 (2-6-62) ~ Disc Aircraft...
Frost, John C. M., et al.

USP # 3,018,068 (1-23-62) ~ Disc Aircraft...
Frost, John C. M., et al.

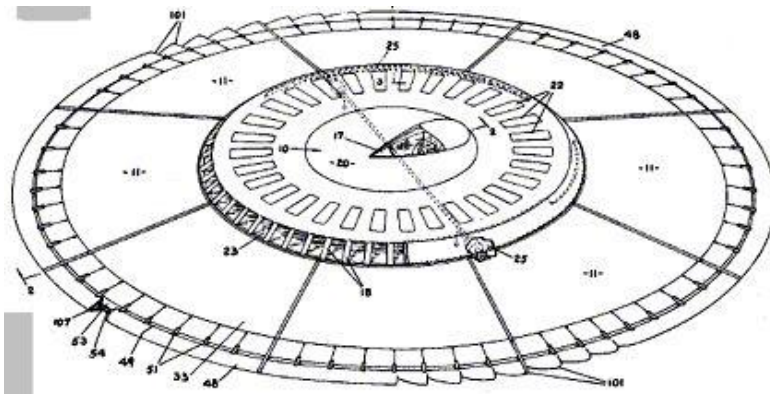

USP # 3,020,002 (2-6-62) ~ VTOL Control
Frost, John C. M.

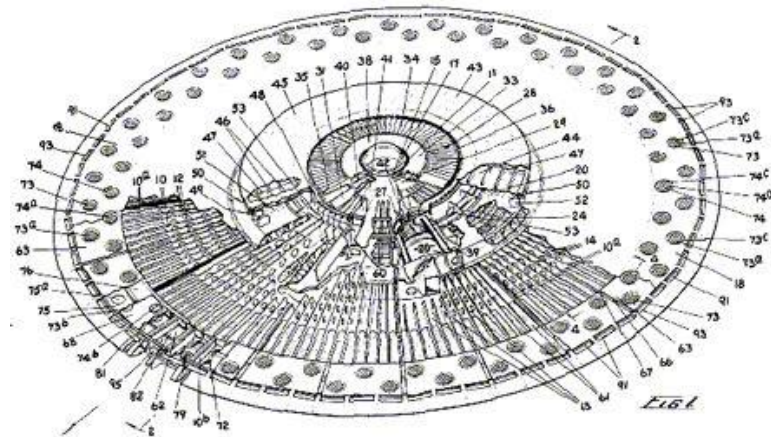

USP # 2,997,254 (8-22-61)~ Gyro-Stabilized
Vertical Rising Vehicle (Discoid)
Mulgrave, Thomas P., et al.

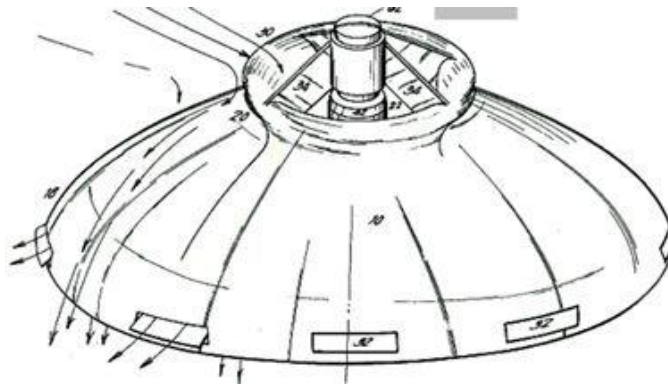

USP # 2,988,303 (6-13-61) ~ Jet-Sustained
Aircraft
Coanda, Henri

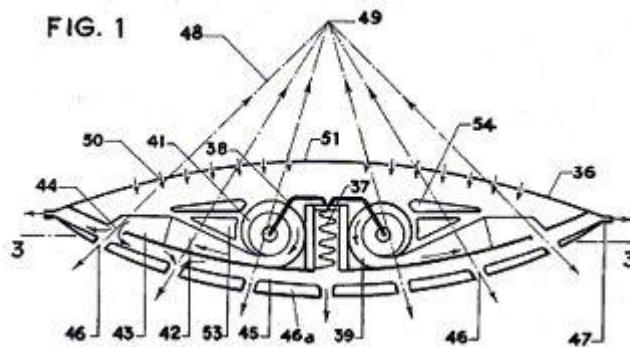

USP # 2,953,320 (9-20-60) ~ Aircraft with Ducted Lifting Fan
Parry, Robert D.

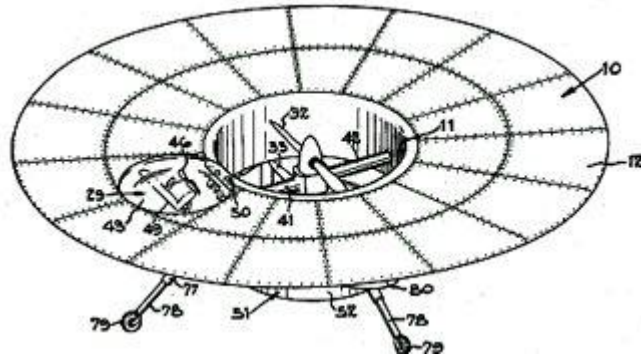

USP # 2,944,762 (7-12-60) ~ Aircraft
Lane, Thomas R.

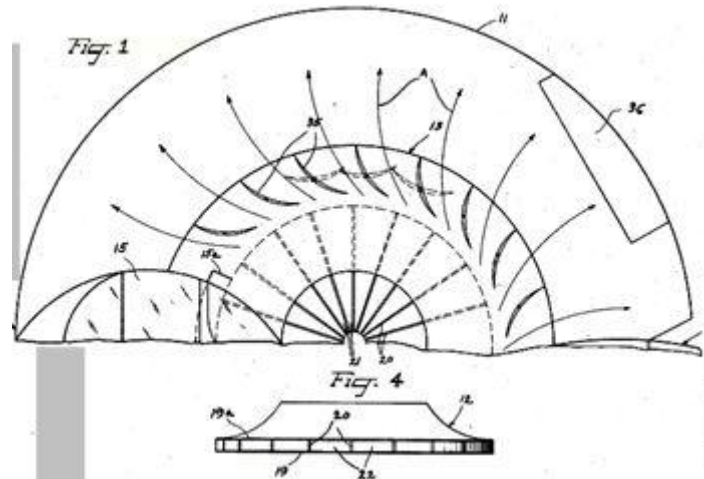

**USP # 2,939,648 (6-7-60) ~ Rotating Jet Aircraft
with Lifting Disc Wing...**
Fleissner, H.

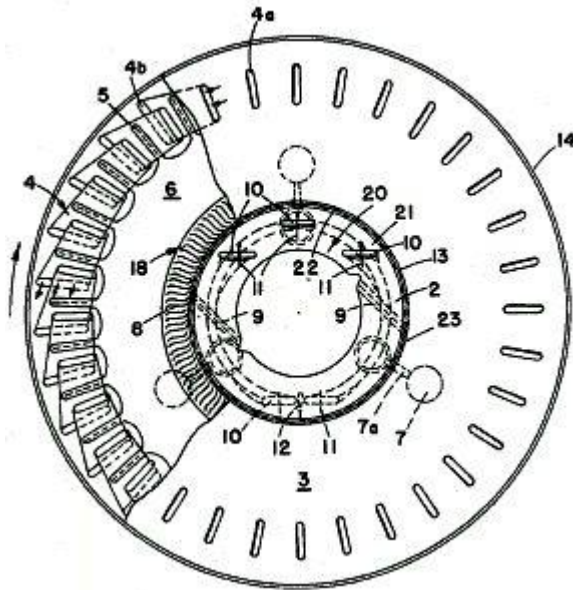

**USP # 2,937,492 (5-24-60) ~ Rotary Reaction
Engine**
Lehberger, Arthur N.

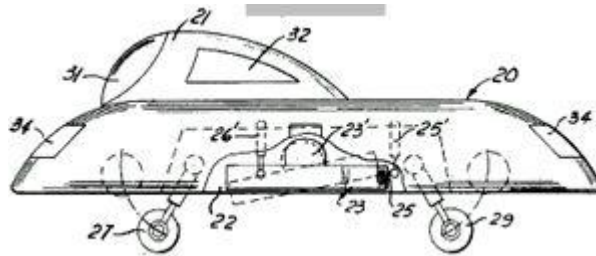

USP # 2,935,275 (5-3-60) ~ Disc-Shaped Aircraft
Grayson, Leonard W.

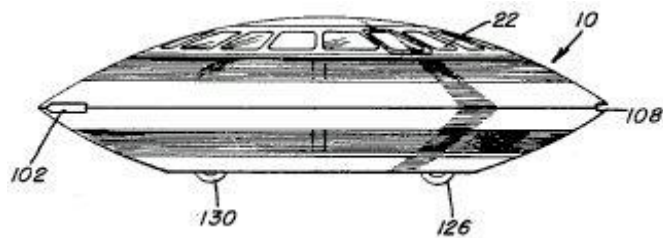

USP # 2,927,746 (3-8-60) ~ Toroidal Aircraft
Mellen, Walter R.

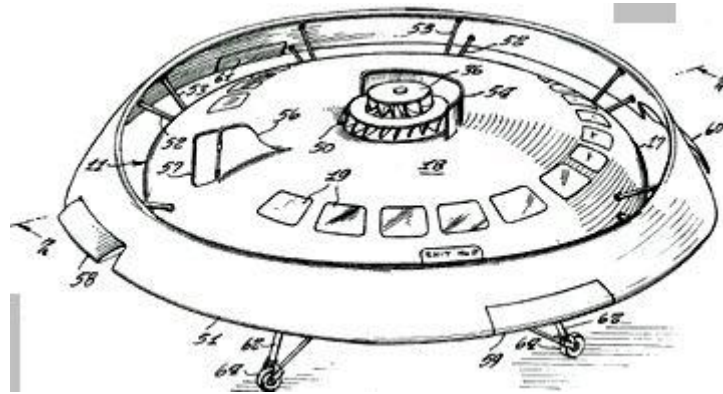

USP # 2,918,230 (12-22-59) ~ Fluid-Sustained & Fluid-Propelled Aircraft
Lippisch, Alexander M.

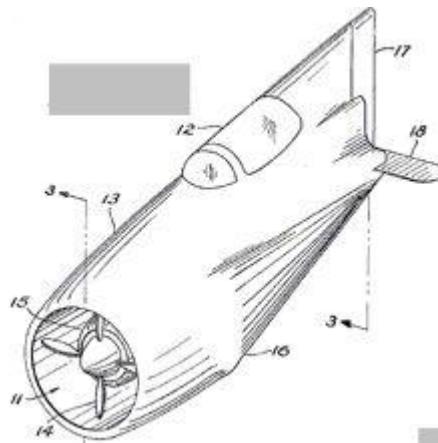

USP # 2,876,965 (3-10-59) ~ Circular Wing Aircraft...
Streib, Homer F.

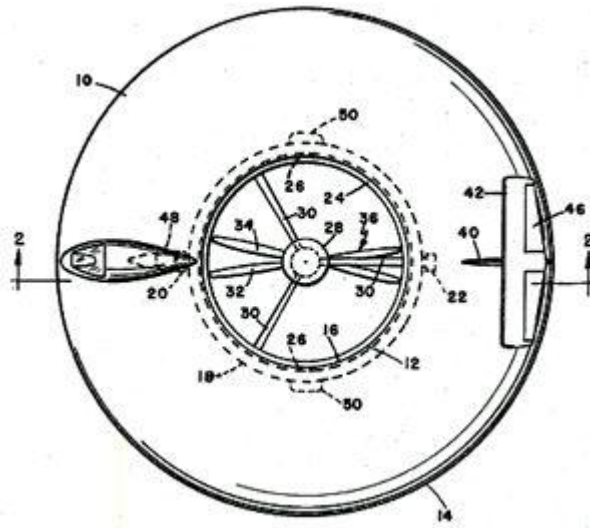

USP # 2,863,621 (12-9-58) ~ Vertical & Horizontal Flight Aircraft
Davis, John W.

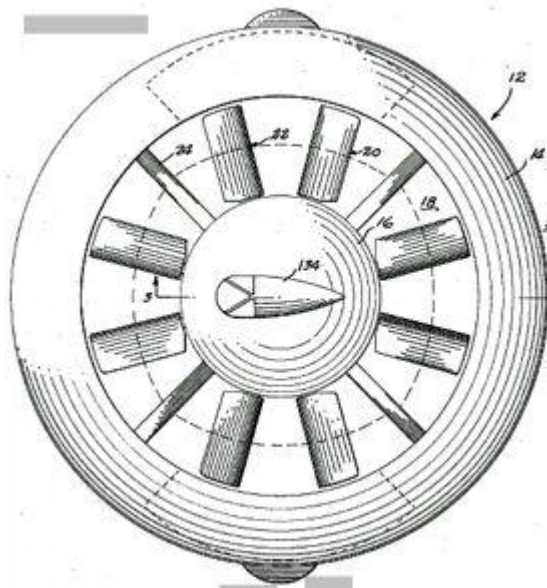

USP # 2,801,058 (7-30-57) ~ Saucer-Shaped Aircraft
Lent, Constantin P.

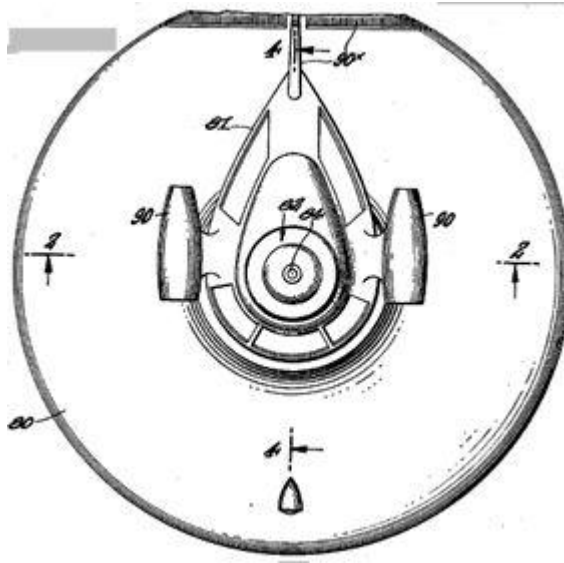

USP # 2,777,649 (1-15-57) ~ Fluid-Sustained Aircraft
Williams, Samuel B.

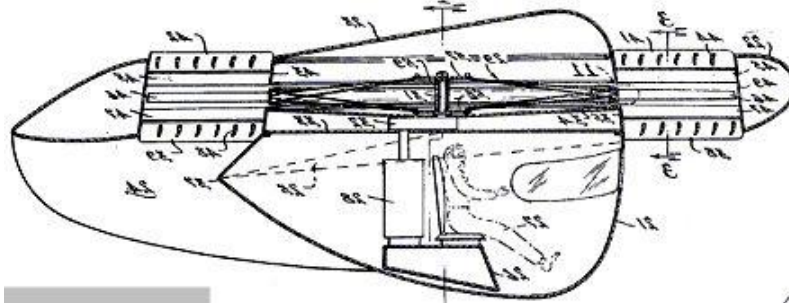

USP # 2,772,057 (11-27-56) ~ Circular Aircraft
&c..
Fischer, John C.

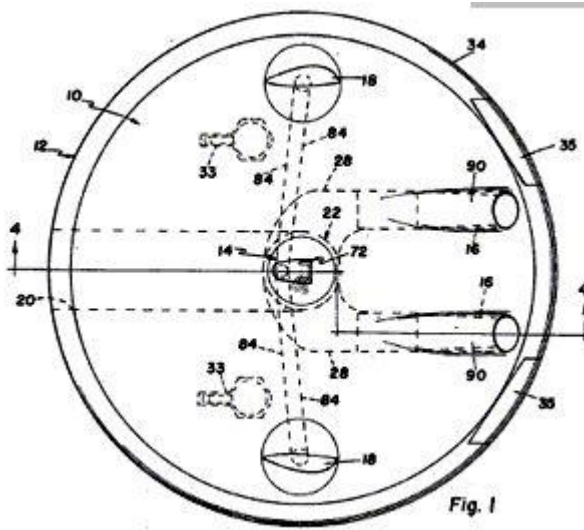

USP # 2,736,514 (2-28-56) ~ Convertible Aircraft
Ross, Robert S.

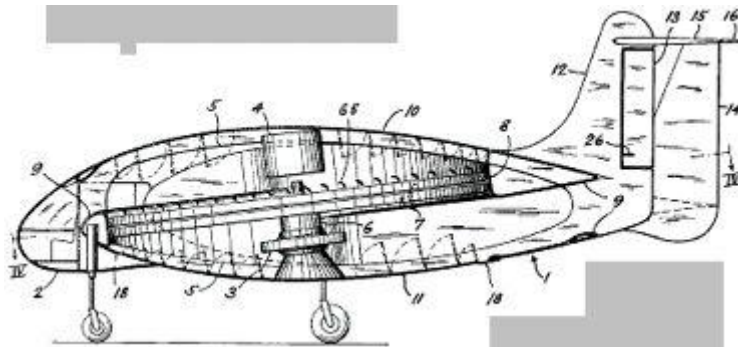

**USP # 2,730,311 (1-10-56) ~ Impeller Propelled
Aerodynamic Body
Doak, Edmond R.**

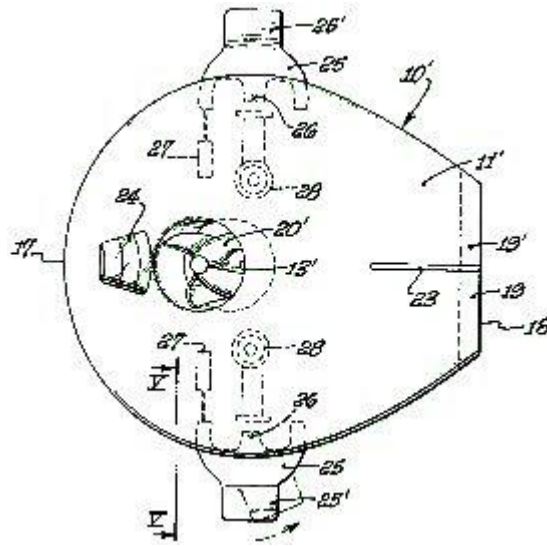

**USP # 2,718,364 (9-20-55) ~ Fluid-Sustained &
Propelled Aircraft...
Crabtree, E.L.**

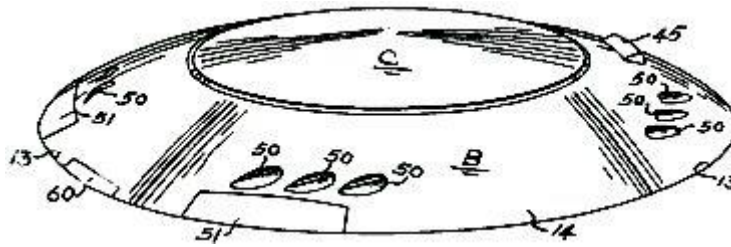

**USP # 2,619,302 (11-25-52) ~ Low Aspect Ratio
Aircraft
Loedding, Alfred C.**

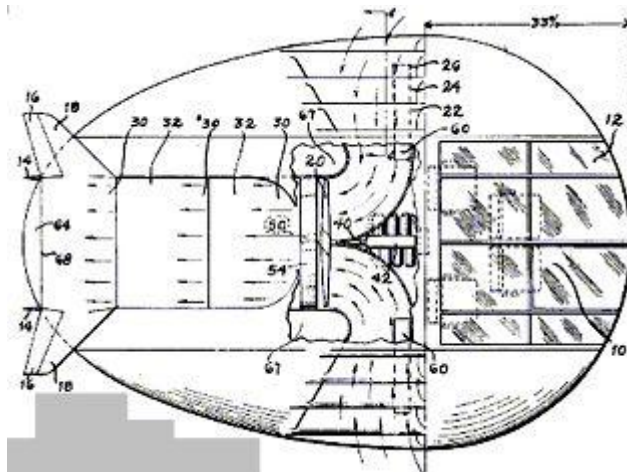

**USP # 2,567,392 (9-11-51) ~ Fluid-Sustained
Aircraft
Naught, Harold**

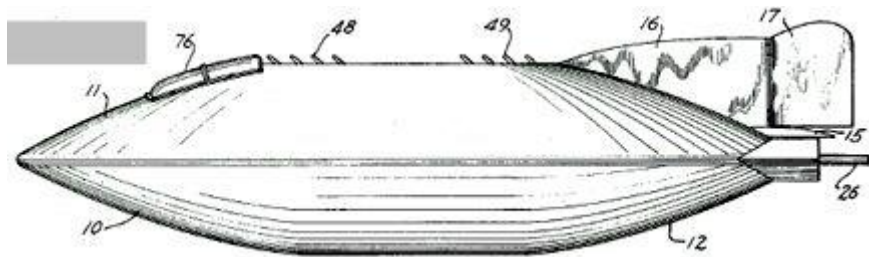

**USP # 2,431,293 (11-18-47) ~ Airplane of Low
Aspect Ratio
Zimmermann, Charles H.**

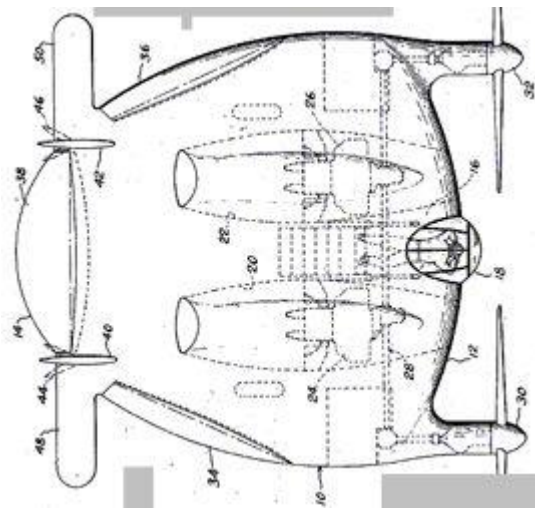

**USP # 2,377,835 (6-5-45) ~ Discopter
Weygers, Alexander G.**

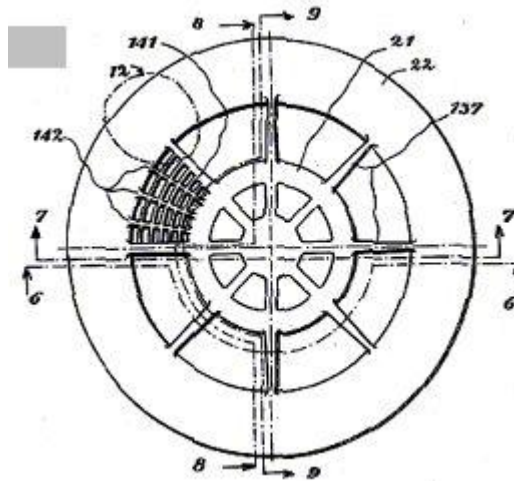

**USP # 1,887,411 (11-8-32) ~ Aircraft
Construction
Johnson, R. B.**

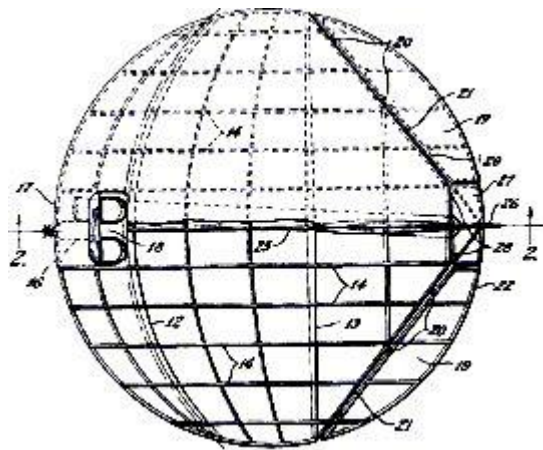

Rex Research, POB 19250, Jean, NV 89019 USA